

# British Columbia Service Entrance Requirements for Residential Building Up to Two Units

TELUS Communications Inc. is responsible for providing and installing the network wiring to the property, and the owner/developer is responsible for providing a suitable pathway (trench, conduit, aerial support etc.) as stipulated by TELUS Communications Inc. from the property line to the building service Provider Demarcation Location.

**Aerial Service** – If the drop wire crosses a street or lane to reach the house, the minimum placing clearance is 5.3m above the crown of the road. If the minimum road clearance cannot be maintained, a clearance pole will be requested by TELUS to be installed. This will provide the minimum required CSA clearance in all weather conditions. So, if your house is a low ranch style, to ensure adequate road clearance it may be necessary to place a mast. Telephone drop wire may attach to the same mast as electrical utility. **If this is done, a minimum of a 300mm separation must be kept between electrical utility and TELUS wires.**

For aerial service, the following materials, available at electrical suppliers, are required: Weatherhead, EMT (metal) or PVC (plastic) with UV inhibitor conduit, pull string and a metal distribution box (in- wall) or plastic network interface box (NIB) (surface mounted). A conduit size of 32mm (1 1/4") min. allows for placing of TELUS and CATV service wire to the building. Please contact your local CATV representative for their requirements.

If the conduit is to support the drop wire from the pole then a minimum of 50mm HDG iron pipe must be used.

**Grounding** – TELUS recommends that a No. 6 insulated ground wire be provided from the power service ground to the Network Interface Box (NIB). This is the maximum size conductor required by the Canadian Electrical Code and therefore ensures that grounding will be adequate to accommodate future growth of the communication installation. Please note that the minimum size of ground wire that TELUS will accept is a No.10 insulated ground wire. See Canadian Electrical Code Section 60-704.

The grounding conductor placed in the distribution box or NIB should then be directly connected to the grounding conductor of the buildings consumer service. As the next (least recommended) alternative, the distribution box or NIB grounding conductor may be attached to the power service electrical equipment enclosures (if allowed by the electrical inspector). Where the power grounding conductor is run within a metal conduit, the distribution box or NIB grounding conductor should be bonded to that conduit.

This ground wire should be as short as possible (as a guideline it should be less than 6m) with as few bends as practical (sweep bends only). It must be permanent and, where needed, guarded from mechanical injury. An approved connector should be used for all connections.

**Note:**

- 1 A minimum 300mm clearance must be maintained in all directions between TELUS wires and electrical utility wires.
- 2 TELUS wires may be attached to the electrical utility mast for support below the electrical utility wires (300mm clearance). The maximum height of the TELUS service attachment point shall be 9m maximum.
- 3 The maximum height of the TELUS service attachment point shall be 9m maximum. Electrical utility wires cannot be attached to the TELUS mast for support in order to meet CEC clearance requirements.
- 4 TELUS' policy is to place the protector/demarcation blocks on the first building on which the drop or entrance cable attaches, except, when no service is required at the first building and the entrance cable conduit is continuous to the second building.
- 5 On single family homes all wires placed beyond the demarcation point (termination point of the entrance cable or drop) is classified as inside wire and is the responsibility of the owner.

**Typical Single Family Residence**

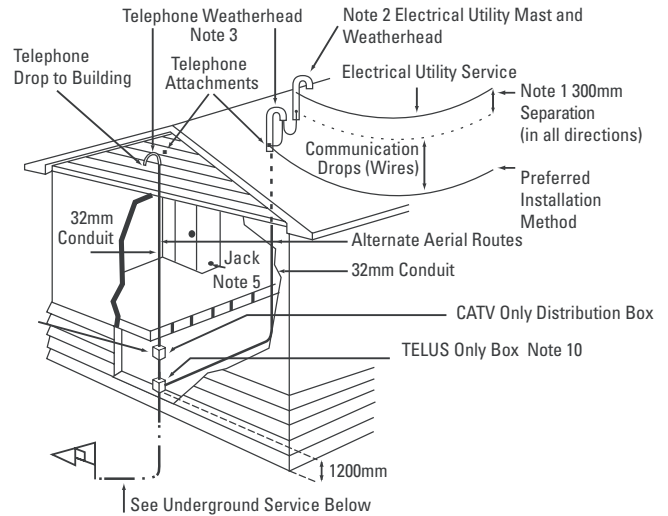

**Typical Section (In-Wall)**

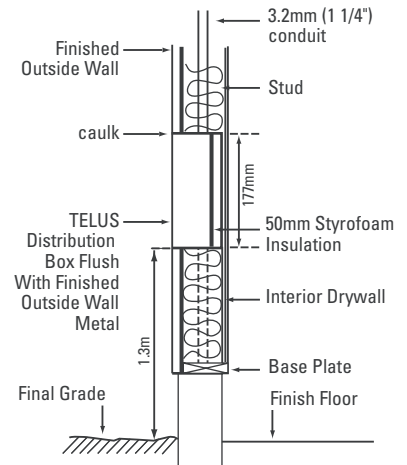

**Demarcation Boxes**

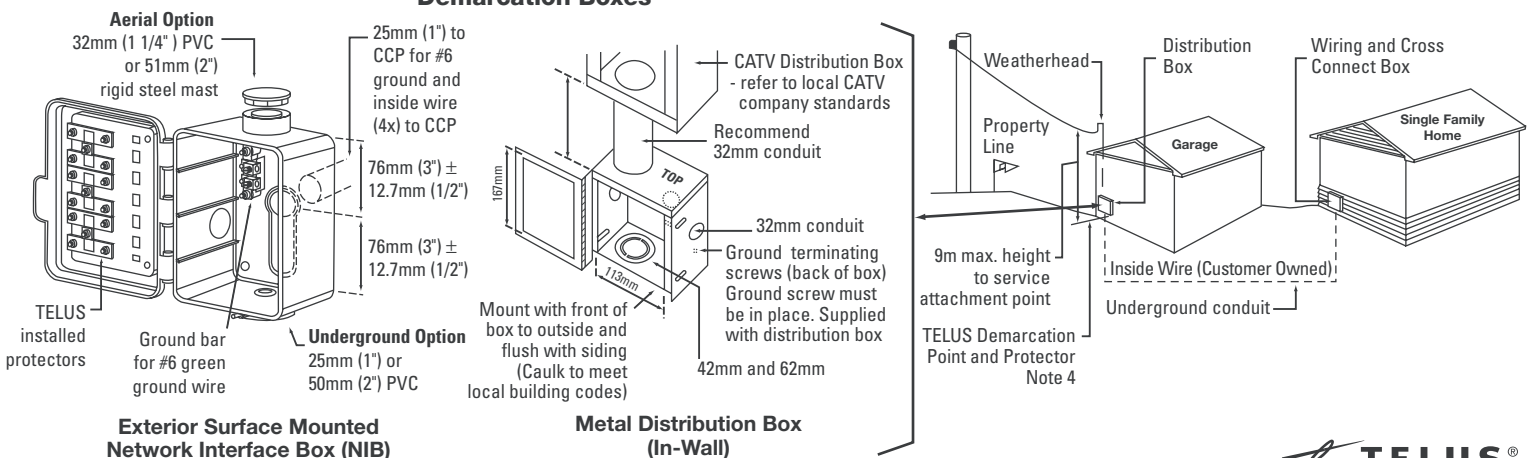

# Mobile Home on Private Property

Mobile home owners are required to provide either:

- 1) a mast with weatherhead (see reverse side for Aerial Service) extended down within 1300mm ± 200mm of final grade or
- 2) a post 100mm x 100mm (4"x4") x 1300 ± 200mm above final grade for underground service.

A Network Interface Box provided by the owner/builder is required for aerial or underground service. TELUS will install protection and demarcation devices inside the NIB. At least one inside wire run must extend into the NIB where it can be attached to the demarcation device.

The building owner is required to supply a No.6 AWG insulated ground wire to the NIB.

## Underground Service

Figure A-#1 The owner/builder is responsible for supplying all material and civil work (to TELUS specifications) on private property.

Figure B-#2 All duct material will be orange in colour (50mm PVC-DB2 Conduit • 50mm PVC-DB2 Coupler).

Figure B-#2A 50mm PVC-DB2 300mm radius bend or 90° 50mm schedule 40 rigid PVC J-Bend (orange).

Figure B-#3 The owner/builder is to make the physical connection at the TELUS specified point-of-connection.

Figure A-#4 TELUS conduit must be on the property line side of the trench with 300mm separation from electrical utility conduit. No crossover of TELUS conduit and electrical utility is permitted.

Figure A-#5 The minimum cover above conduit to 0.45m (1.5ft) or the same depth as electrical utility.

Figure A-#6 All material used for back-filling must be select fill, clear of all rocks and sharp stones unless otherwise specified.

Figure A-#6A Native fill free of rock larger than 150mm.

Figure B-#7 Extend conduit 1.3m above the final grade into the distribution box or NIB. Pull string to be 3mm braided nylon cord.

Figure B-#7A Owner/builder to provide drain in 90° bend into drain rock, by perforating the bend on the bottom side.

Figure B-#8 No installation can have more than 2-90° or equivalent bends (2x45° = 1x90°) without the use of a pull box. Pull boxes or L bends must not be used in place of a bend.

Figure B-#9 Maximum pulling length 60m (200ft) through 2-90° (300mm radius) bends or 90m (300ft) on a straight pull.

Figure B-#10 Owner/builder to provide and install the metal in-wall distribution box or plastic surface network interface box (NIB).

Figure B-#11 Owner/builder to ensure that TELUS and electrical utility conduit exit the concrete at minimum 300mm separation.

Figure B-#12 Depending upon foundation type, and local bylaws conduit can be attached to exterior. (All exposed PVC conduit must have UV inhibitors). (See Figure B-#10)

Figure B-#12A The exposed 50mm (2") orange conduit may be reduced to 25mm (1") grey conduit above the finished grade level. Do not glue the coupler reducer to the 50mm conduit, as access to the larger conduit may be required in the future.

Figure B-#13 All above requirements are subject to local Building Inspector's approval.

Note: All materials supplied by owner/developer are available at electrical supply outlets.

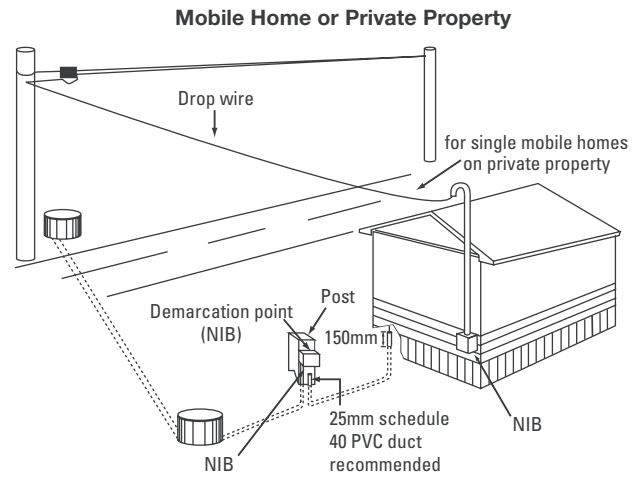

Typical Section Thru Trench – FIGURE A

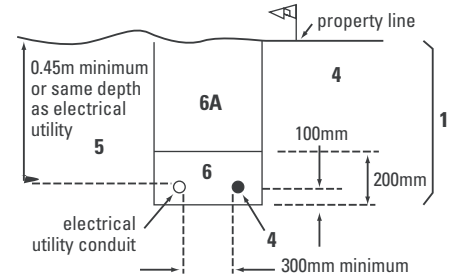

Typical Section Thru Trench – FIGURE B (In-Wall)

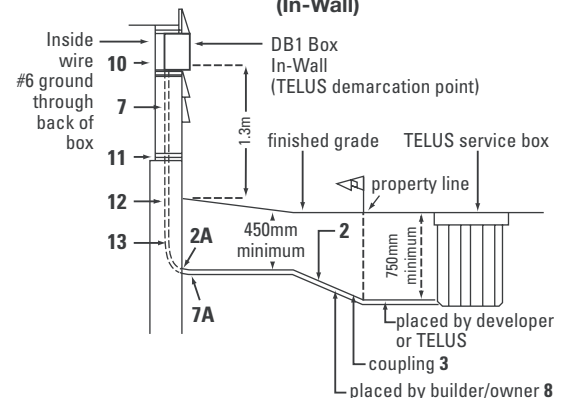

Typical Section Thru Trench – FIGURE B (cont) (Exterior Wall)

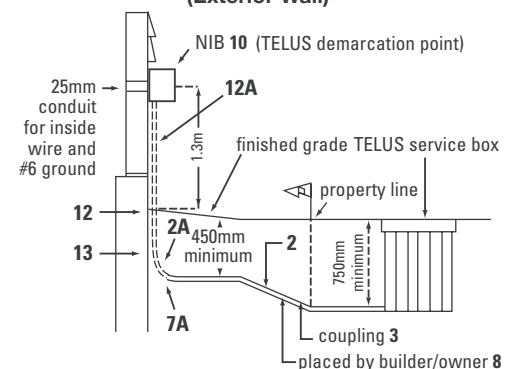

## Reference

<b>CSA</b> Canadian Standards Association	<b>EMT</b> Electrical Metal Tubing
<b>CEC</b> Canadian Electrical Code	<b>HDG</b> High Density Gauge
<b>CATV</b> Community Antenna Television	<b>UV</b> Ultra Violet
<b>PVC</b> Polyvinyl Compound	<b>DB2</b> Direct Buried Type 2 Conduit
<b>AWG</b> American Wire Gauge	<b>NID</b> Network Interface Device (TELUS Protectors)
	<b>NIB</b> Network Interface Box (Surface)

**TELUS Prewire Offices 1-800-665-5259**

For additional information see [telus.com/bics](http://telus.com/bics)

P546 (Rev. 05-2005)  
N5120560K  
GA00074-02

**TELUS®**